

Concrete Mixer Truck slim

The **siti** mixer you know,
now lighter and more durable.



Do the math:

$$\begin{array}{ccccc} \img alt="hourglass icon" data-bbox="295 772 382 842" & + & \img alt="feather icon" data-bbox="462 772 528 842" & = & \img alt="dollar sign icon" data-bbox="628 772 692 842 \\ \text{durability} & & \text{lightness} & & \text{economy} \end{array}$$

For every Slim Concrete Mixer
sold, a tree will be planted.



Slim Concrete Mixer Truck

Drum body, mixing blades and reinforcements, built in special steel with high performance against abrasion, aiming at greater durability with less weight.



1

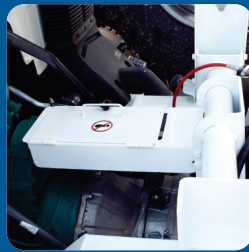

Gimbal with easy access protection.

2



Lighter water tank with a capacity of 300 liters, avoiding waste.

3



The best hydraulic set (reducer, motor and hydraulic pump) available on the market.

4



Drum manufactured with noble materials, adding lightness and durability.

5



Cylindrical ring produced with special material and process for greater durability.

6



The only one on the market manufactured with a system of double support rollers on each side (04 pieces in total) mounted on top-notch bearings with seals.

7



Discharge hopper with closed design, preventing leakage of material.

8



Ladder with non-slip steps and expanded sheet metal platform, which is also easier to clean.

9

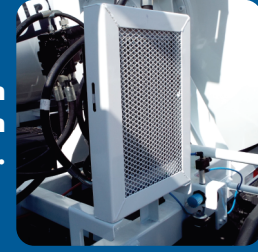

Hydraulic system with heat exchanger with superior performance.

10



Concrete mixer chassis manufactured in highly rigid tubular profile reducing material accumulation and customized, according to the truck model.

11



Greater drum mounting inclination, favoring transport on slopes.

12



Lighter extension rails made of high-quality plastic performance, facilitating the handling by the operator.

13



Chassis manufactured in a single piece, avoiding assemblies and screws, adding greater stability to the equipment.

14



Rear bumper with INMETRO approval.

Distribution of forces

Computer simulations in finite element software, aiming at the optimization of the materials and components used, always with the guarantee of SITI quality and durability.

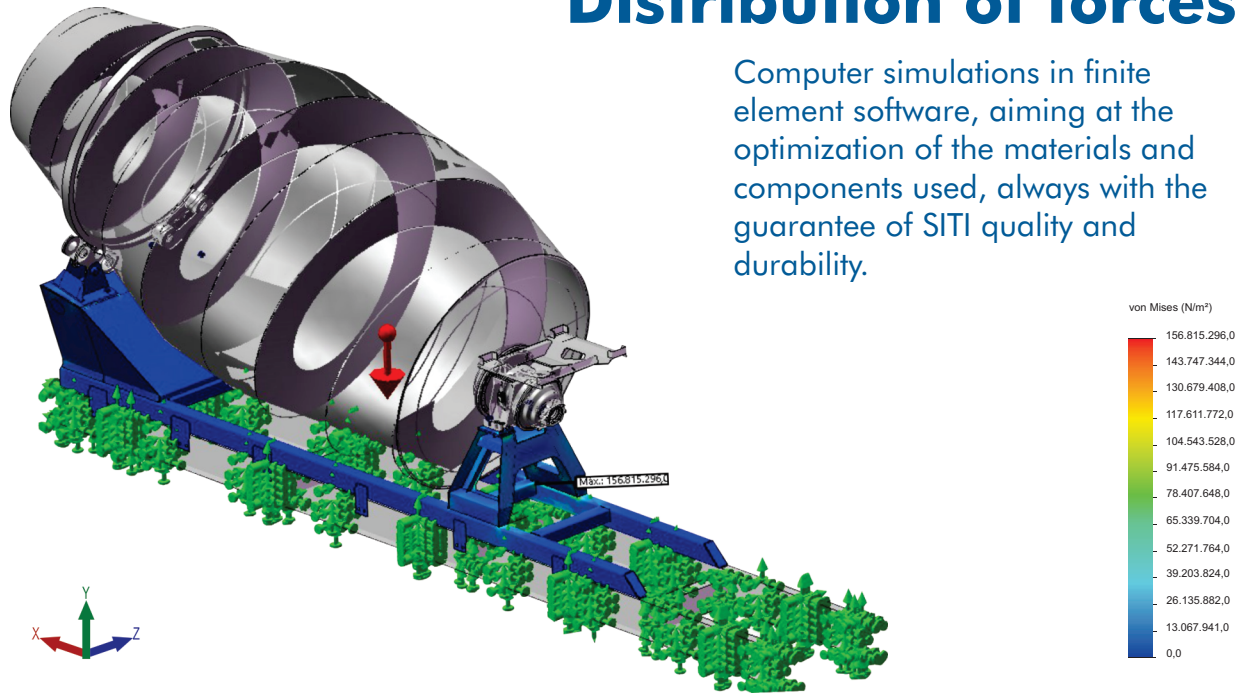

Specifications

MODEL		SL8
Drum Load Capacity	M ³	8
Drum Geometric Volume	M ³	13,1
Maximum Drum Rotation	rpm	16
Water Tank	Liters	300
Total Oil Reservoir	Liters	60
Operating Oil Volume	Liters	30
DIMENSIONS		SL8
Total Length (A)	mm	6710
Chassis Length (C)	mm	5700
Total Height (B)	mm	2700
Center of Gravity (loaded) (S)	mm	2220
Drum Diameter (D)	mm	2250
Roller Diameter	mm	200
Drum Angle (E)	----	14°
Structure Weight	Kg	3500

*Reference values, subject to change without prior notice.

**Dimensions may vary by truck model.

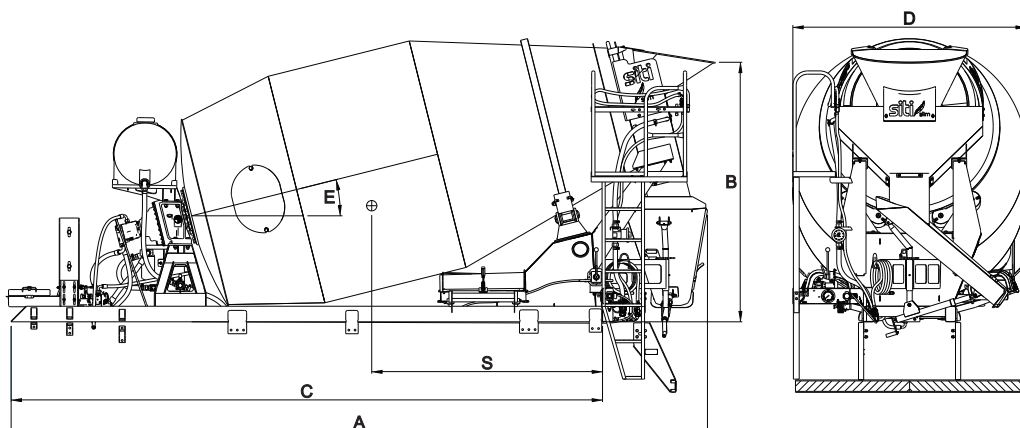

Mixing Blades

Longa Vida

The "Longa Vida" (meaning 'long life') mixing blades and reinforcements are built with high performance materials, ensuring durability with less weight.

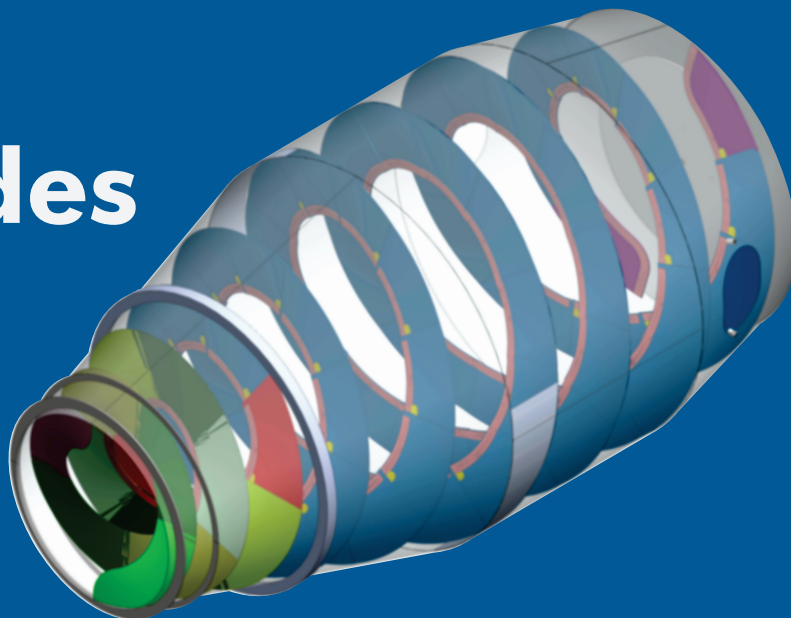

Painting

The concrete mixers are fully blasted and painted in polyurethane paint type background/finish with application of several coats, according to the SITI quality standard, following the colors and logo of each client.

The SITI Slim Concrete Mixer, in addition to being very well studied to bring benefits to those who acquire it, also helps the environment.

- The lighter equipment saves fuel, consequently reduces the emission of polluting gases.
- The water tank with a smaller volume prevents unnecessary waste of this important asset.



In addition, we at SITI are committed to planting a tree for every Slim Concrete Mixer sold.

Suécia Avenue, Jd. Santa Terezinha – Mogi Guaçu City – São Paulo State
ZIP CODE 13848-315 | Brazil

Phone: +55 (19) 3891-9700 | E-mail: siti@siti.com.br | Website: www.siti.com.br